

Pin configuration

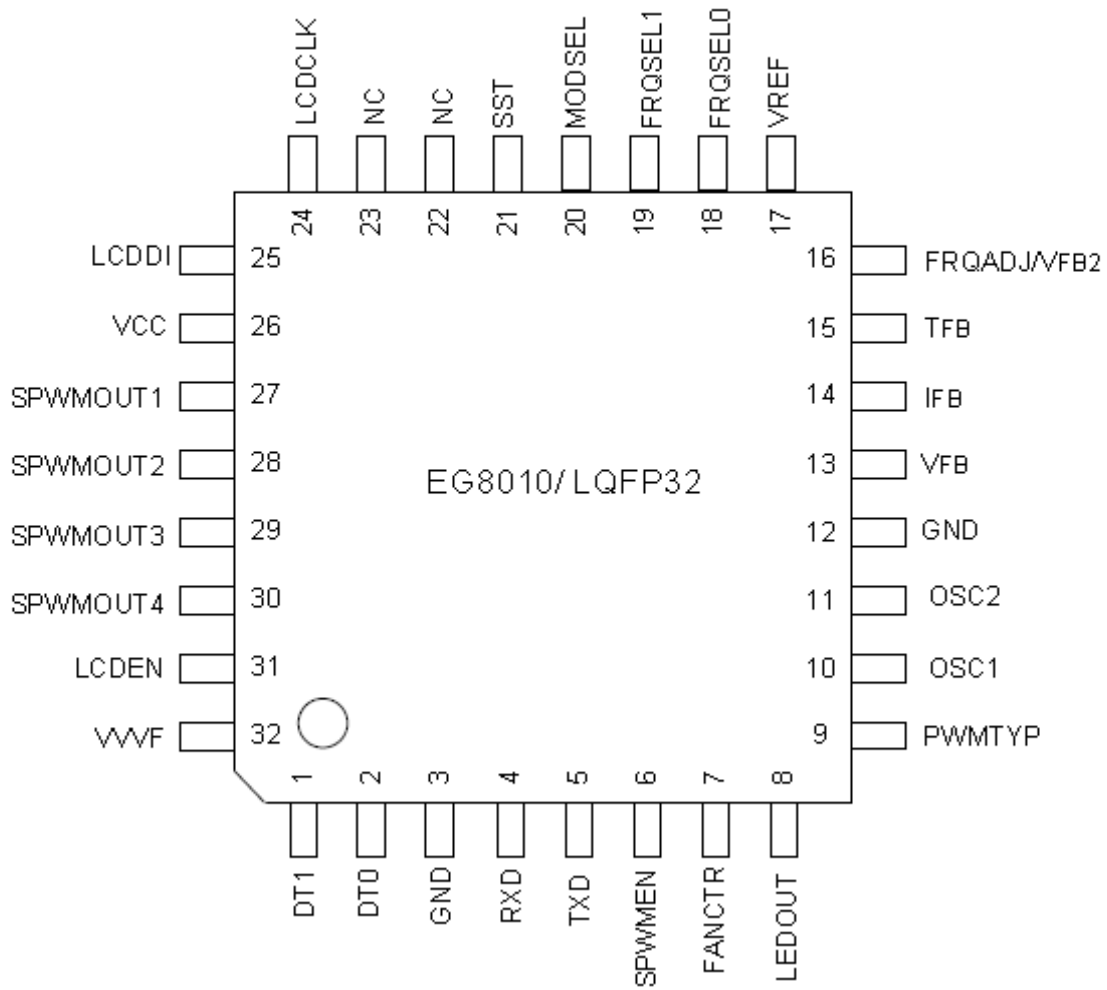

26	VCC	VCC	+5 V power supply terminal of the chip
----	-----	-----	--

3,12	GND	GND	The ground terminal of Chip
1	DT1	I	DT1, DT0 is set PWM output, under the MOS tube dead time: "00" is 300ns dead time; "01" is 500ns dead time; "10" is 1.0us deadtime; "11" is 1.5uS dead time...
2	DT0	I	
4	RXD	I	Serial communication data receiving end
5	TXD	O	Serial communication data sender
6	SPWMEN	I	The SPWM output enable, "1" start SPWM output, "0" Close the the SPWM output of serial data communications sender
7	FANCTR	O	An external fan control, When TFB pin detects a temperature higher than 45 ° C, the output high "1" so that the fan runs after running temperature is below 40 ° C, output low level "0" the fan to stop working
8	LEDOUT	O	Outside the external LED alarm output when a fault occurs, output low level "0" to turn on the LED Normal: long bright Overcurrent: flashing, and off for 2 seconds, has been circulating Overvoltage: blinking 3, off for 2 seconds, has been circulating Undervoltage: 4 flashing, off for 2 seconds, has been circulating Fan control to When TFB pin is detected when the temperature is higher than 45 ° C, the output high "1" so that the fan runs, running temperature is below 40 ° C, the output low level "0" the fan to stop working
			Over-temperature: 5 Next flashing off for 2 seconds, has been circulating
9	PWMTYP	I	PWM output type selection "0" is the positive type of PWM output, used in active-high driver IR2110 drive the device, the pin SPWMOUT is high open power MOS "1" is the type of negative polarity PWM output applied to the active low drive optocoupler TLP250 internal diode cathode pin SPWMOUT open is low power MOS Application design can refer to Typical Application Circuit, the rational allocation of state of the pin according to the driving device, or inconsistencies on the cause, under the power MOS turn-on phenomenon
10	OSC1	I	12M crystal oscillator pin 1
11	OSC2	I	12M crystal oscillator pin 2
13	VFB	I	Sine wave output voltage feedback input
14	IFB	I	Load current feedback input
15	TFB	I	Temperature feedback input
16	FREQ ADJ/ VFB2	I	Multiplexed pin, the FM mode (the unipolar modulation) as the FM voltage 0-5V input, bipolar modulation as the right leg output voltage feedback input
17	VREF	I	Chip internal reference power input
18	FRQSEL0	I	

19	FRQSEL1	I	In FRQSEL1 (pin 19), FRQSELO (pin 18) is to set the frequency mode, "00" is the output frequency of 50Hz; "01" is the output frequency of 60Hz; "10" is the adjustment of the output frequency range 0-100Hz by FRQADJ pin; "11" is the output frequency range 0-400Hz by FRQADJ pin adjustment
20	MODSEL	I	Unipolar, bipolar modulation options: "0" is the unipolar modulation mode; "1" is a bipolar modulation scheme
21	SST	I	The soft-start function enable input: "0" is not supported by the soft-start function; "1" is to support the soft-start function, the soft-start time for 3S
22,23	NC	-	
24	LCDCLK	O	Serial 12832 LCD module clock output
25	LCDDI	O	Serial 12832 LCD module instructions, data output of
27	SPWMOUT1	O	Right arm of bridge SPWM output unipolar modulation of the foot as the right bridge the fundamental output arm tube, bipolar modulation as SPWM modulation output
28	SPWMOUT2	O	Right leg tube the SPWM output, unipolar modulation of the foot as the the fundamental output tube in the right leg, bipolar modulation as SPWM modulation output
29	SPWMOUT3	O	SPWM output of the left arm of the bridge tube, unipolar and bipolar modulation of the foot as the left leg SPWM modulation output
30	SPWMOUT4	O	Left leg tube SPWM output unipolar and bipolar modulation of the foot as the left leg SPWM modulation output
31	LCDEN	O	Serial 12832 LCD module output enable terminal
32	VVVF	I	Inverter, transformer function enable pin: "0" is the frequency conversion constant pressure mode; "1" is a variable frequency mode, applied to the inverter and motor control

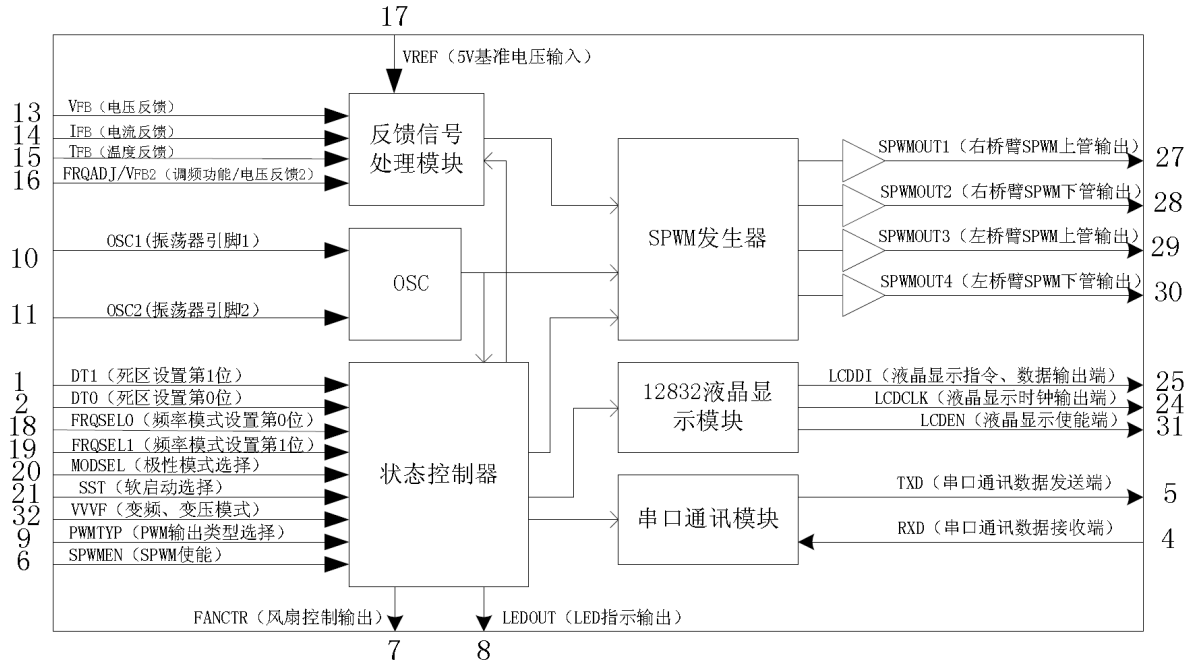

6.1 EG8010 + IR2110S typical application circuit diagram pure sine wave inverter (unipolar modulation)

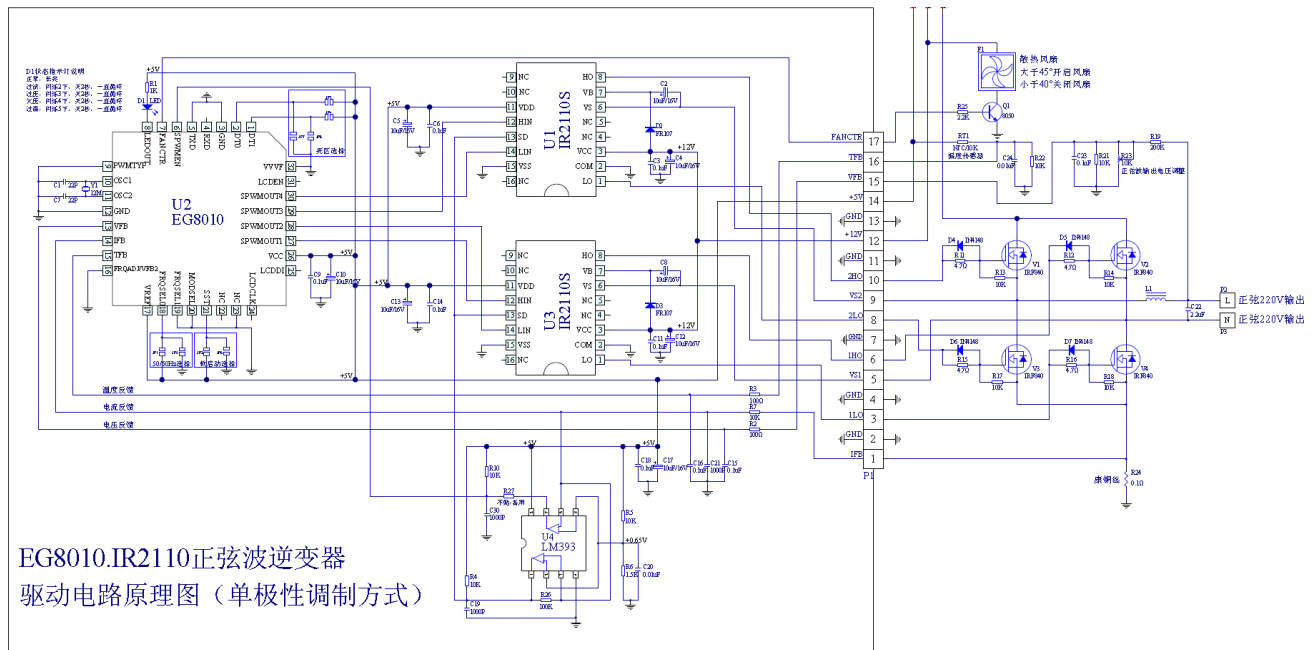

Figure 6-1. EG8010 + IR2110S typical application circuit diagram pure sine wave inverter (unipolar modulation)

1. A fixed frequency mode 50Hz (FRQSEL1, FRQSELO = 00) or 60Hz (FRQSEL1, FRQSELO = 01), FRQADJ/VFB2 and VVVF pin is inactive, the size of the sine wave output voltage to be adjusted by the feedback resistor R23 or regulator can be applied in dimming regulator occasions.

2 fixed voltage variable frequency mode (the VVVF pin to "0" low level) 0 to 100Hz (FRQSEL1 FRQSELO = 10) or 0Hz

to 400Hz (FRQSEL1, FRQSEL0 = 11), FRQADJ pin external potentiometer, the output frequency FRQADJ pin regulator output voltage is set by R23.

(3) variable frequency mode (VVF pin to "1" high) 0 ~ 100Hz (FRQSEL1, FRQSEL0 = 10) or 0Hz to 400Hz (FRQSEL1, FRQSEL0 = 11), FRQADJ pin external potentiometer, FRQADJ pin to regulate the output frequency and output voltage, the internal circuit is maintained

$V / F = \text{constant}$, R23 set the output frequency of 50Hz, the output voltage is 220V

6.2 EG8010 + IR2106S typical application circuit diagram pure sine wave inverter (unipolar modulation)

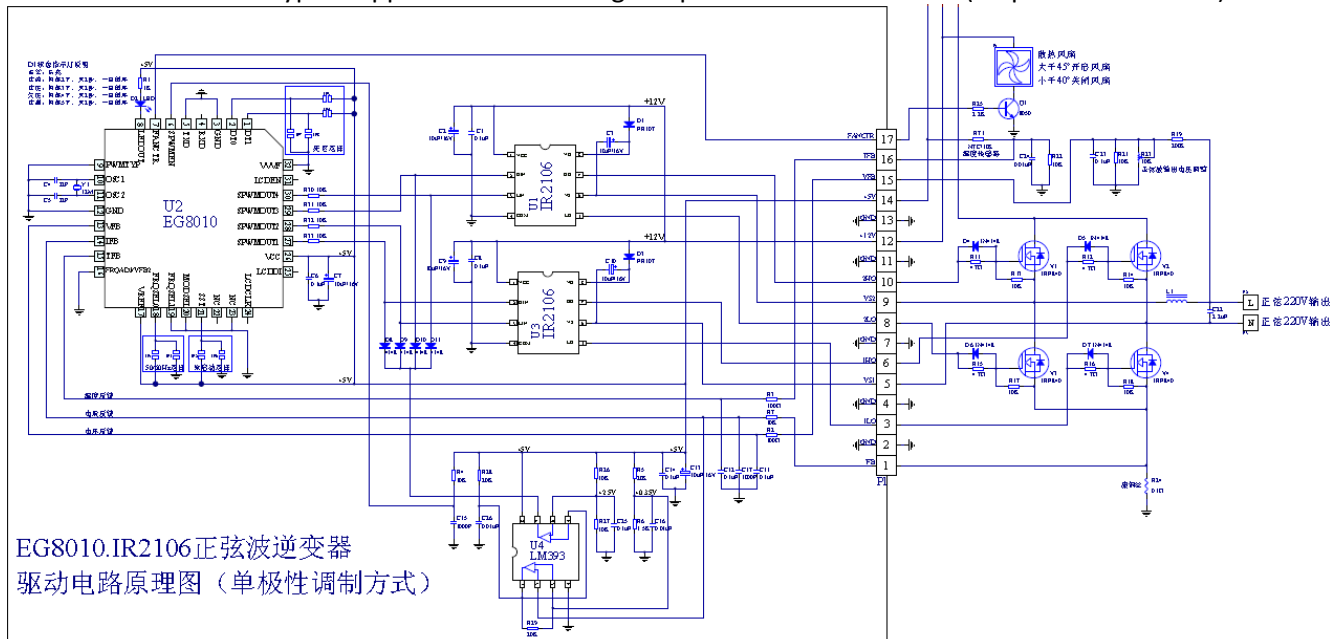

Figure 6-2. EG8010 + IR2106S typical application circuit diagram pure sine wave inverter (unipolar modulation)

A fixed frequency mode 50Hz (FRQSEL1, FRQSEL0 = 00) or 60Hz (FRQSEL1, FRQSEL0 = 01), FRQADJ/VFB2 and VVF pin is inactive, the size of the sine wave output voltage to be adjusted by the feedback resistor R23 or regulator can be applied in dimming regulator occasions.

2 fixed voltage variable frequency mode (the VVF pin to "0" low level) 0 to 100Hz (FRQSEL1 FRQSEL0 = 10) or 0Hz to 400Hz (FRQSEL1, FRQSEL0 = 11), FRQADJ pin external potentiometer, the output frequency FRQADJ pin regulator output voltage is set by R23.

(3) variable frequency mode (VVF pin to "1" high) 0 ~ 100Hz (FRQSEL1, FRQSEL0 = 10) or 0Hz to 400Hz (FRQSEL1, FRQSEL0 = 11), FRQADJ pin external potentiometer, FRQADJ pin to regulate the output frequency and output voltage, the internal circuit is maintained

$V / F = \text{constant}$, R23 set the output frequency is 50Hz output voltage effective value of 220V.

6.3 EG8010 + TLP250 pure sine wave inverter Typical Application Schematic (unipolar modulation)

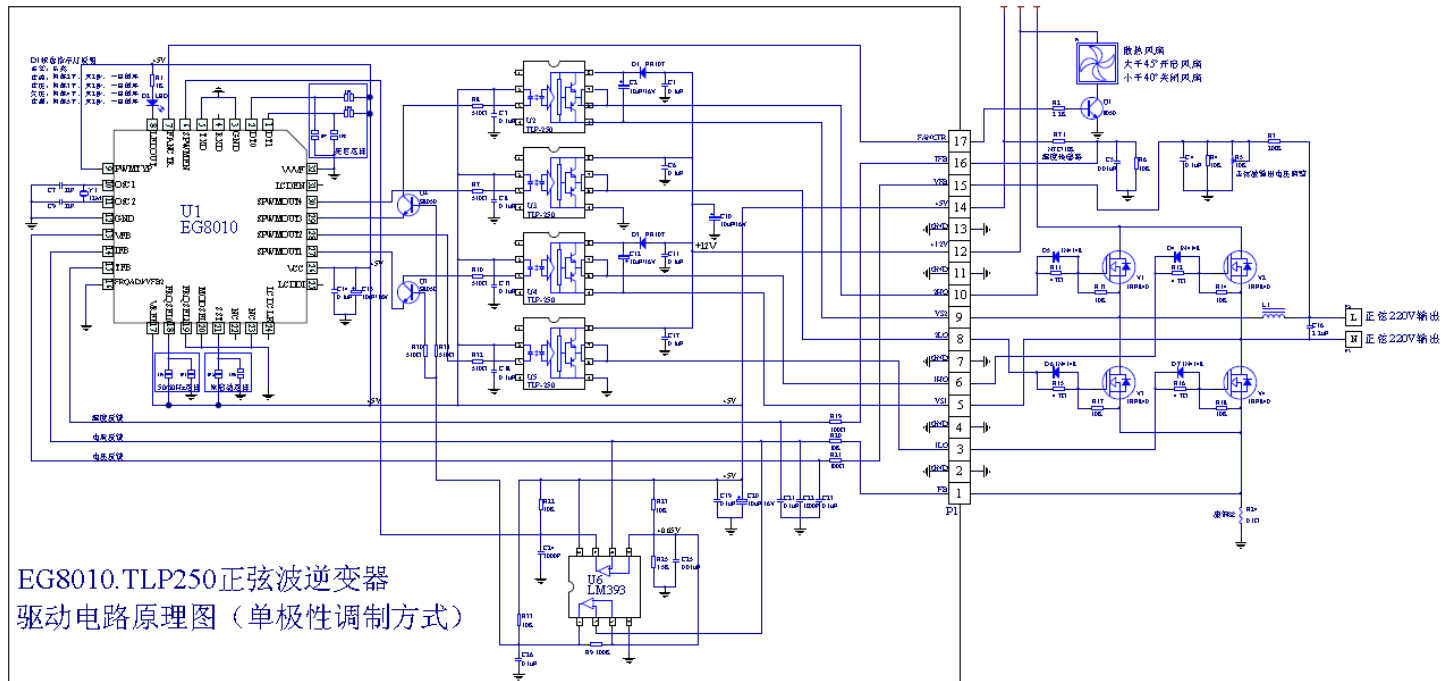

1 fixed frequency mode 50Hz (FRQSEL1, FRQSEL0 = 00) or 60 Hz (FRQSEL1 FRQSEL0 = 01), the size of the sine wave output voltage by the feedback resistor R23 adjustment or regulator can be applied to the the dimming voltage regulator Occasion.

2 fixed voltage variable frequency mode (the VVVF pin to "0" low level) 0 to 100Hz (FRQSEL1 FRQSEL0 = 10) or 0Hz to 400Hz (FRQSEL1, FRQSEL0 = 11), FRQADJ pin external potentiometer, the output frequency FRQADJ pin regulator output voltage is set by R23.

(3) variable frequency mode (VVVF pin to "1" high) 0 ~ 100Hz (FRQSEL1, FRQSEL0 = 10) or 0Hz to 400Hz (FRQSEL1, FRQSEL0 = 11), FRQADJ pin external potentiometer, FRQADJ pin to regulate the output frequency and output voltage, the internal circuit is maintained $V / F = \text{constant}$, R23 set the output frequency is 50Hz output voltage effective value of 220V.

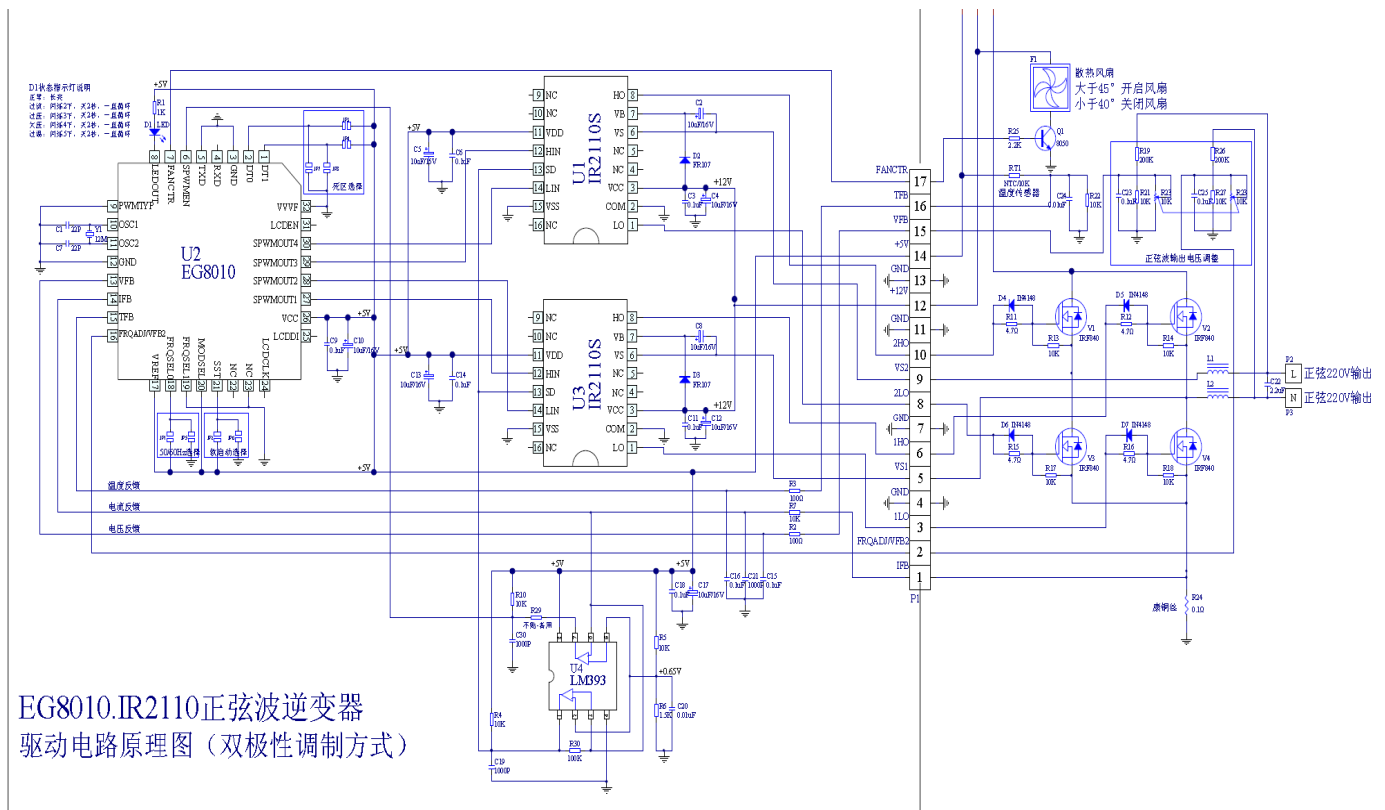

6.4 EG8010 + the IR2110S pure sine wave inverter Typical Application Schematic (bipolar modulation)

1 fixed frequency mode 50Hz (FRQSEL1, FRQSEL0 = 00) or 60Hz (FRQSEL1, FRQSEL0 = 01), bipolar modulation when the pin. 20 (MODSEL) connects the high level, the size of the sine wave output voltage by double The resistor R23 to be adjusted or regulated.

2 Using bipolar modulation does not support FM function.

8.1 Output voltage feedback

EG8010 chip operation modes the unipolar modulation and bipolar modulation, unipolar modulation only leg (the EG8010 pin SPWMOUT3, SPWMOUT4) do the SPWM modulation output, the other leg (the EG8010 pin SPWMOUT1 SPWMOUT2) doing the fundamental output filter inductor when the application needs to be connected SPWM modulation the bridge arm output terminal, the feedback voltage sampling circuit also connected to the output terminal of the inductor in the the SPWM modulation bridge arm, as shown in figure 8.1a. The bipolar modulation Shuangqiaoshan arm (EG8010 pin SPWM3,, SPWM4 SPWM1 SPWM2) at the same time do SPWM modulation output applications use two-way the inductor filter characteristics will be better voltage sampling the feedback circuit requires two voltage divider network to do the differential feedback process, as shown in Figure 8.1c. Unipolar modulation mode, the the EG8010 chip voltage feedback process is VFB2 feedback FRQADJ/VFB2 only FM mode FRQADJ function via pin (13) the VFB measuring inverter output AC voltage, the pin (16) invalid, the circuit structure shown in Figure 8.1a voltage sampling feedback section, the peak voltage measurement feedback and internal reference sine wave peak voltage of 3V error calculation, a corresponding adjustment of the output voltage when the output voltage increases, the pin voltage with an increasing internal circuit error value adjustment factor multiplier factor to reduce the

output voltage reaches the regulation process, on the contrary, increased output voltage when the pin voltage to reduce the chip will be made.

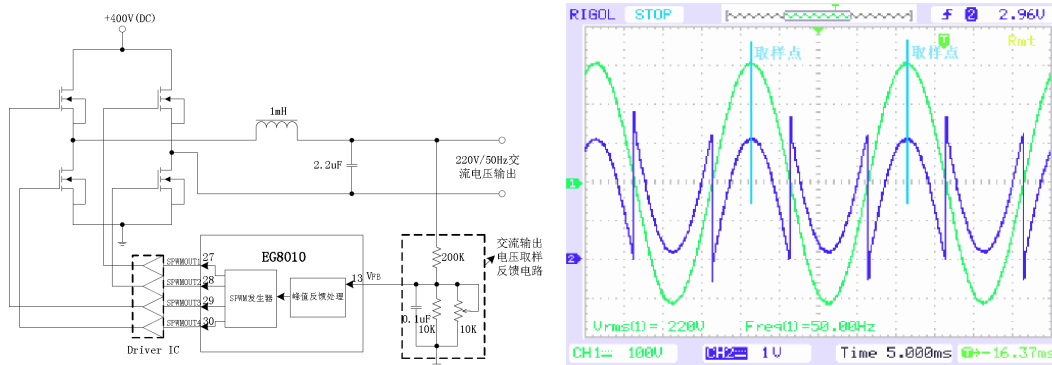

Figure 8.1a EG8010 unipolar modulation output voltage feedback circuit diagram 8.1b measured the SPWM unipolar modulation pure sine wave output waveform and VFB feedback waveform

Figure 8.1b for the actual testing of the unipolar modulation waveform, EG8010 with a peak point sampled output voltage regulator, high precision voltage regulation speed, when for some reason cause the output voltage deviation, such as changes in load or input voltage fluctuations The other factor, EG8010 1-3 AC cycle adjusted to the desired output voltage.

Bipolar modulation mode, the the EG8010 chip voltage feedback process is to measure the right leg of the output voltage via pin (13) the VFB measuring the left leg of the output voltage and the pin (16) FRQADJ/VFB2 VFB2 function only this when FRQADJ FM function is disabled, the circuit structure shown in Figure 8.1c voltage feedback section, two differential feedback to measure peak differential voltage and internal reference sine wave peak voltage of 3V error calculation, a corresponding adjustment to the value of the output voltage, the internal circuit error multiplier coefficients of adjustment factor value calculated to achieve the regulation process, bipolar modulation can also be adjusted to a desired output voltage within 1-3 AC cycle.

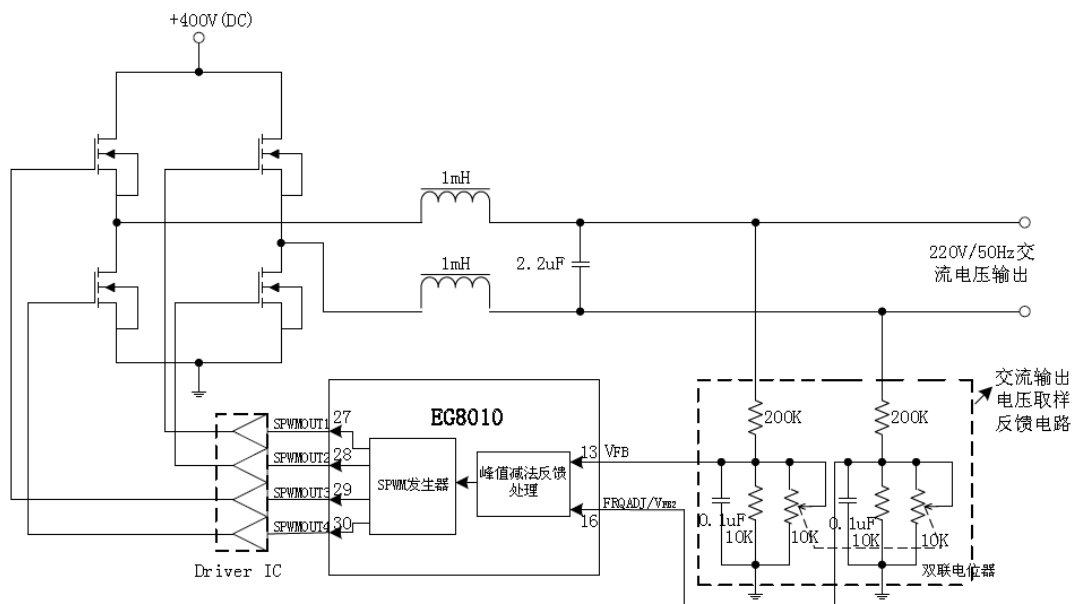

Figure 8.1c EG8010 the bipolar modulation output voltage feedback circuit

The 2.75V extension in order to prevent too low or high output voltage supplied to the load, EG8010 internal set overvoltage and undervoltage protection, overvoltage protection settings 3.15V delay time of 300ms, undervoltage protection settings when time is 3S, when the occurrence of an overvoltage or undervoltage protection, EG8010 according to the set state PWMTYP of the pin (9) will output the of SPWMOUT1 to of SPWMOUT4 to "0" or "1" level, so that the output voltage to turn off all power MOSFET low, once the overvoltage and undervoltage protection, EG8010 will be released in the 8S re-open the power MOSFET, then determine the output voltage, release opened the duration of the power MOSFET 100ms, 100mS time of the release of the judgment or undervoltage event, if there are still overvoltage or undervoltage event, EG8010 then turn off all power MOSFET allows the output voltage to low, waiting for re-8S release, normal operation if the release of more than 1 minute EG8010 Clear -or undervoltage event times, or continuous release of the cumulative number of times 5 times still does not run EG8010 will completely shutdown SPWM module output requires the system to power on again after release.

8.2 Output current feedback

The EG8010 chip pin IFB is a measure of the output load current of the inverter, is mainly used for overcurrent detection, the circuit structure shown in Figure 8.1a current sampling feedback part, the internal base peak voltage of the pin is set to 0.5V overcurrent detection a delay time of 600ms, when somehow causes high load current exceeds the load current of the inverter will output a SPWMOUT1 SPWMOUT4 to "0" or "1" level-EG8010 according to the setting state of the pin (9) PWMTYP, Close all power MOSFET allows the output voltage to a low level, the main function is to protect the power MOSFET and load, Once in the over-current protection, EG8010 will be released in the 16S re-open the power MOSFET to determine the load overcurrent condition, the release of open power MOS The duration of the tube for 100mS, the release time of 100mS Classifying an overcurrent event, if there is still an overcurrent event, the EG8010 and then turn off all power MOSFET causes the output voltage to a low level, re waiting for the release of 16S, if after releasing normal running for more than 1 minute the EG8010 clears the overcurrent number of incidents, otherwise the number of continuous release of accumulated five times there are still not operating normally EG8010 will be completely off the SPWM module output requires the system to power on again after release. If some occasions, such as start-up current is relatively large time is relatively long, not suitable for the application of this feature, you can IFB pin to ground.

The 8.3 temperature detection feedback

The EG8010 chip pin TFB is to measure the operating temperature of the inverter, is mainly used for temperature protection testing and operating temperature output to 12832 LCD module, the circuit structure shown in Figure 8.3a temperature detection circuit, as shown NTC thermistor resistor RT1 and measuring resistor RF1 is composed of a simple voltage divider circuit and the divided voltage value varies with the temperature value changes the value, the size of this voltage will reflect the size of the NTC resistor thereby obtaining the corresponding temperature value. NTC selection of 25 ° C corresponds to the resistance of 10K thermistor over-temperature TFB pin voltage is set at 4.3V, when over-temperature protection, EG8010 set according to the pin (9) PWMTYP state output SPWMOUT1 ~ SPWMOUT4 "0" or "1" level, turn off the Power MOSFET output voltage to low Once in the

over-temperature protection, EG8010 will re-determine the operating temperature, if the the TFB pin voltage is lower than 4.0V, EG8010 will exit the over-temperature protection, the inverter work properly. If you do not use over-temperature protection, this pin needs to be grounded.

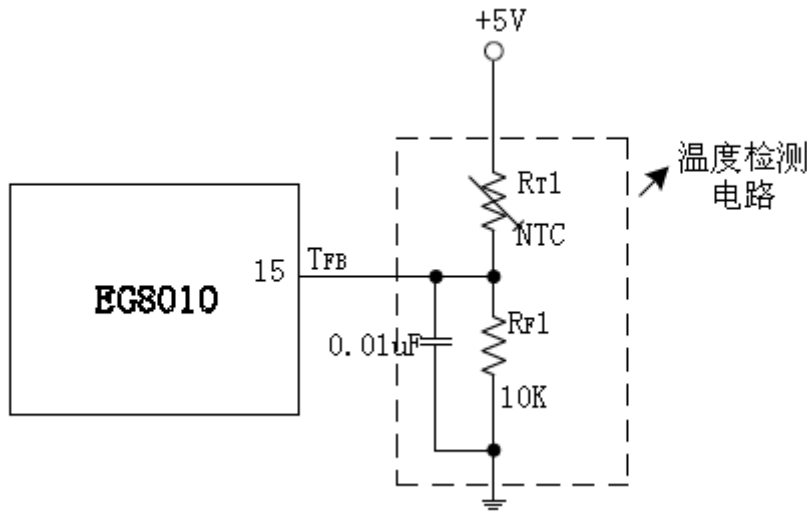

The Figure 8.3A EG8010 temperature detection circuit

8.4 PWM Output Type

The EG8010 pin chip PWMTYP of is to set the PWM output type, PWMTYP is "0" is the type of positive polarity PWM output level is applied to the dead zone Low occasions (such as driver IR2110 IR2106 driver chips) Figure 8.4a the EG8010 the pin SPWMOUT the output waveform, active high drive power MOS transistor, 8.4b is PWMTYP = "0" when the positive polarity PWM type drive IR2110 application circuit.

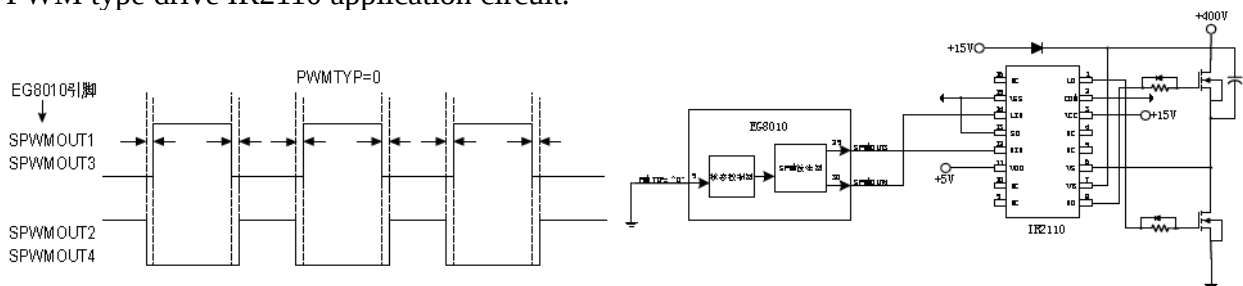

Figure 8.4a EG8010 positive polarity type of PWM output Figure 8.4b EG8010 positive polarity PWM driver IR2110

PWMTYP "1" is a type of negative PWM output is applied to the level of the dead zone at the same time high Occasion (e.g. driver TLP250 optocoupler cathode), the EG8010 the pin

SPWMOUT the output waveform is shown in Figure 8.4c, LOW effectively drive the optocoupler output high drive power MOS transistor, the Figure 8.4d PWM TYP = "1" when the the negative PWM type drive TL250 optocoupler application circuit.

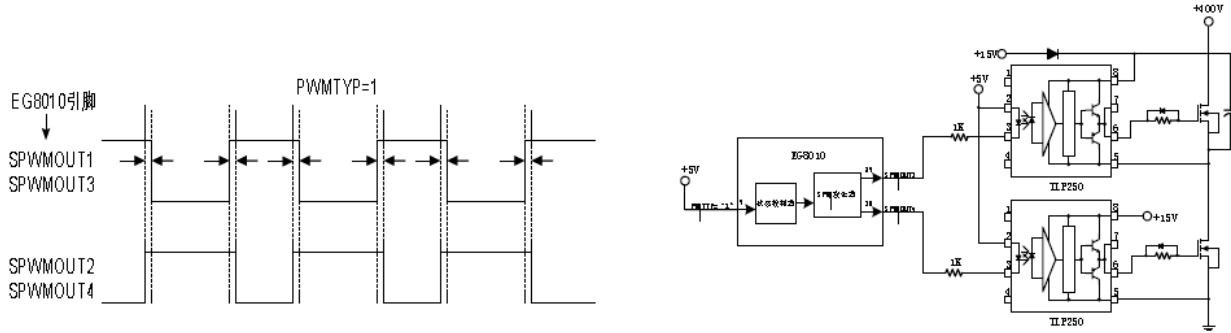

Figure 8.4c EG8010 the negative PWM type output the Figure 8.4d EG8010 negative PWM drive TLP250 optocoupler

8.5 deadtime settings

The the the EG8010 chip pin DT1, DT0 control dead time, dead-time control is one of the important parameters of the power MOS, if no dead time or too small can cause upper and lower power MOS transistors are turned on simultaneously burned the phenomenon of MOS transistor If the dead zone too waveform distortion and power tube heat a serious phenomenon Figure 8.5a is the EG8010 internal deadtime control timing, as shown pin DT1, DT0 to set four kinds of dead time, "00" is 300ns dead area, "01" is 500ns dead time, "10" is 1uS dead time, "11" is 1.5us deadtime.

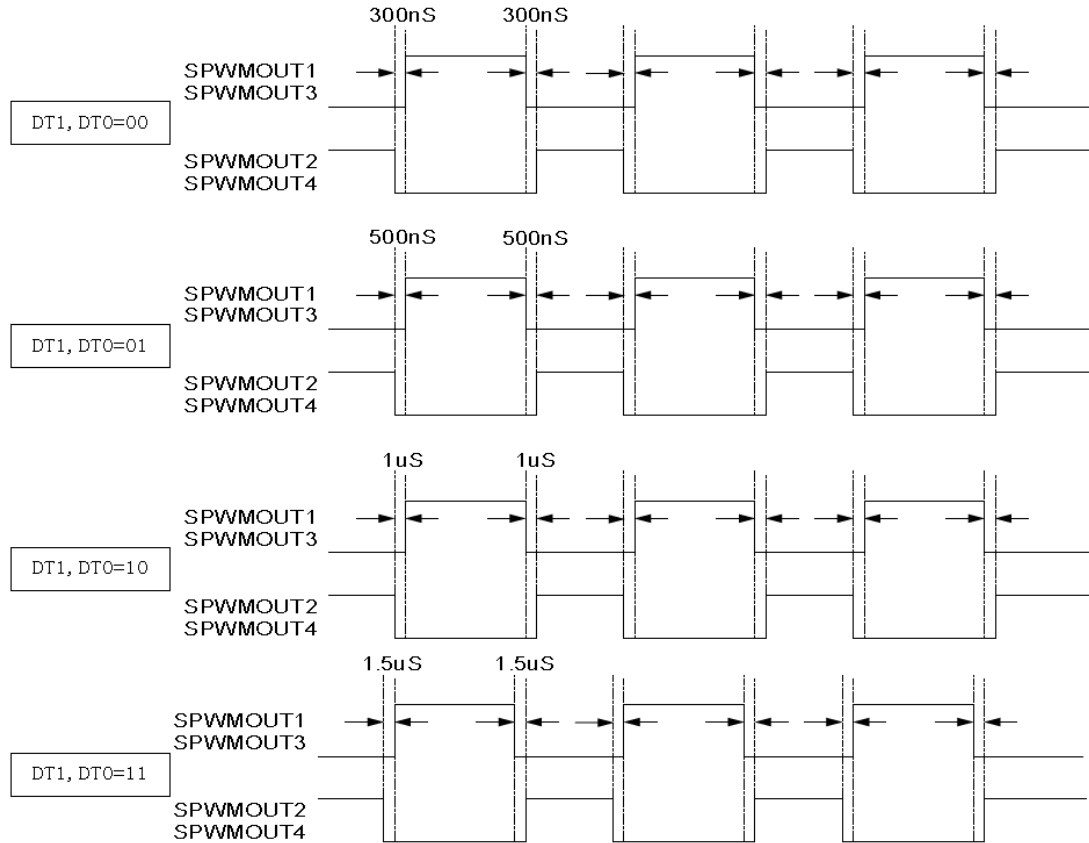
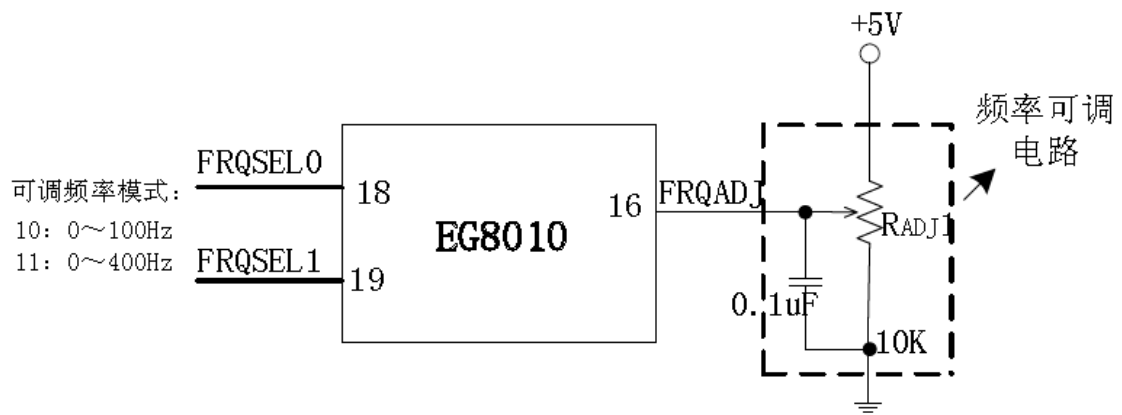

Figure 8.5a EG8010 dead zone control settings

8.6 Frequency setting

The EG8010 frequency mode is divided into fixed-frequency mode and adjustable frequency mode, adjustable EG8010 only unipolar modulation frequency mode, you can adjust the frequency mode, the pin (20) MODSEL low-level access. Frequency mode via pin FRQSEL1, FRQSEL0 set fixed frequency mode "00" is the output frequency of 50Hz, "01" is output to the 60Hz frequency, fixed frequency mode invalid FRQADJ function to work in the bipolar modulation mode pin (16) as VFB2 voltage feedback circuit; adjustable frequency mode to "10" output frequency range from 0 to 100Hz adjustable, "11" is the output frequency range 0 to 400Hz adjustable, adjustable frequency by FRQADJ pin adjustment circuit, such as Figure 8.6a, FRQADJ pin input voltage varies from 0 ~ 5V, corresponding to the fundamental output frequency from 0 to 100Hz or 400Hz changes, this function combines the VVVF pin can be used in single-phase inverter system. 8.5 deadtime settings

The the the EG8010 chip pin DT1, DT0 control dead time, dead-time control is one of the important parameters of the power MOS, if no dead time or too small can cause upper and lower power MOS transistors are turned on simultaneously burned the phenomenon of MOS transistor If the dead zone too waveform distortion and power tube heat a serious phenomenon Figure 8.5a is the EG8010 internal deadtime control timing, as shown pin DT1, DT0 to set four kinds of dead time, "00" is 300ns dead area, "01" is 500ns dead time, "10" is 1µs dead time, "11" is 1.5µs deadtime.



The Figure 8.6a EG8010 frequency regulation circuit